

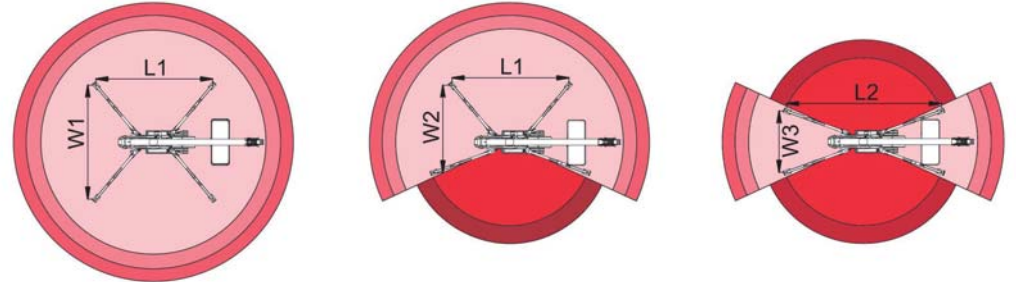

32 m ↑
14,5 m →
330 Kg 🧑🧑🧑

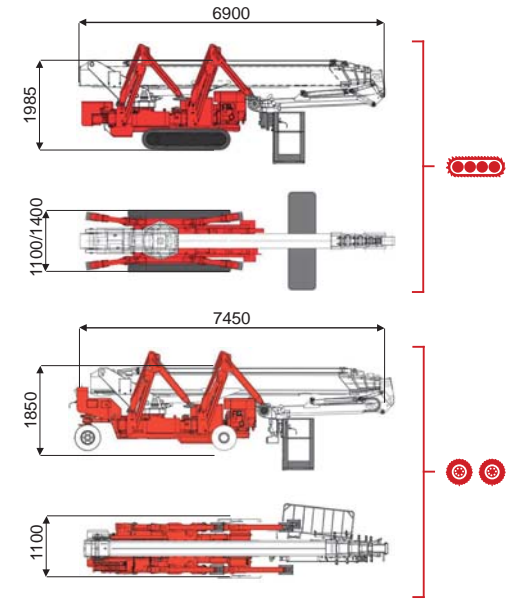
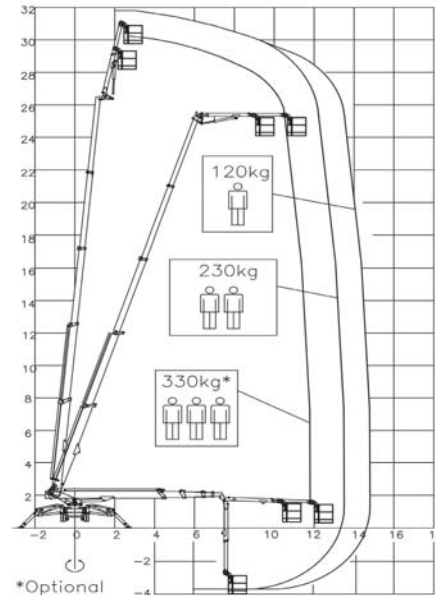

| | | | | | | | | | |
|----------|----------|----------|---------|------------|---------|---------|---------|---------|---------|
| 12000 mm | 13500 mm | 14500 mm | 7400 mm | 10500 mm | L1 | L2 | W1 | W2 | W3 |
| 330 kg | 250 kg | 120 kg | 330 kg | 120/230 kg | 5113 mm | 6445 mm | 4743 mm | 3781 mm | 2823 mm |

BI-ENERGY
Diesel+AC



| | | | | | | | | | | | | | | | | | | | |
|----------|----|------|--------|--------|------|------|-----------|---------|-----------|-----|-----|----------|---------|-------|------------|------------|--------------|---------|---------|
| XTJ 32/C | 🔋 | 32 m | 14,5 m | 330 kg | 175° | 540° | 180x70 cm | 90°+80° | 2,8-4,7 m | 15% | 40% | 3,0 km/h | 5940 kg | 35 kN | 2,62 kN/m² | 4,53 kN/m² | 1100/1400 mm | 6900 mm | 1985 mm |
| XTJ 32/R | 🔋🔌 | 32 m | 14,5 m | 330 kg | 175° | 540° | 180x70 cm | 90°+80° | 2,8-4,7 m | 15% | 40% | 2,5 km/h | 5940 kg | 35 kN | 2,62 kN/m² | 4,53 kN/m² | 1100 mm | 7450 mm | 1850 mm |



Battery type



Battery charge



Add. Weight



Autonomy



Charging time

Electropump

| | | | | | | | | |
|--------|-----------|----|-------------|--------------|--------|---------------|----|------------|
| ECO | DC+AC | 🔋🔌 | 48V 320 A/h | 230V-48V 45A | 450 kg | 6-7 h endless | 7h | 48V 12 kW |
| HYBRID | Diesel+DC | 🔋🔌 | 24V 240 A/h | 230V-24V 35A | 200 kg | 2-3 h endless | 7h | 24V 5,5 kW |