

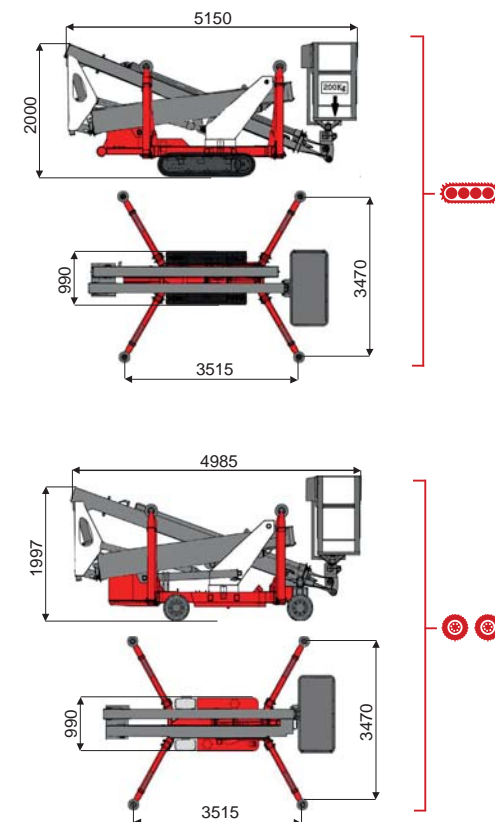

19 m ↑
8,5 m →
200 Kg 👤 👤

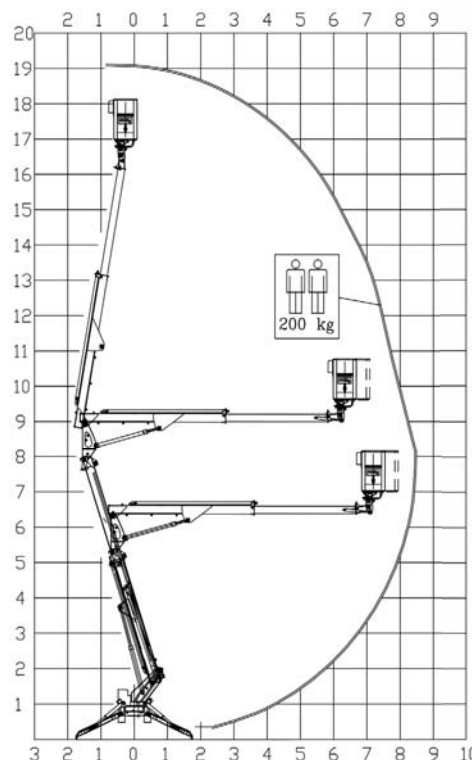

BI-ENERGY Diesel+AC																		
TZX 190/C																		
TZX 190/R																		

ECO	DC+AC						
		Battery type	Battery charge	Add. Weight	Autonomy	Charging time	Electropump
		24V 240 A/h	230V-24V 40A	230 kg	3-4 h endless	6h	24V 5.5 kW