

SJIII 3215/19

ELECTRIC SCISSOR LIFTS



STANDARD FEATURES

- DC motor controller
- Drivable at full height
- Variable speed, front two wheel hydraulic drive
- 90° Steering (zero inside turning radius)
- Dual holding brakes
- Proportional controls for drive & lift functions
- 3' (0.91 m) Roll out extension deck
- 24V DC Power source
- Low voltage battery protection
- 30% Gradeability
- Solid rubber, non-marking tires
- Pothole protection system
- 110V AC Outlet on platform with GFI
- 28 mph Wind rating (12.5 m/s)
- Tilt alarm with drive & lift cut-out
- All motion audible alarm
- Lanyard attachment points
- Operator horn
- Forklift pockets and tie down/lift lugs
- Relay based control system
- SKYCODED™ color coded and numbered wiring system
- Telematics ready

ACCESSORIES AND OPTIONS

- Flashing light
- Dual flashing lights
- Extended control box cable
- Light duty pipe rack
- Heavy duty pipe rack
- Tool caddy
- Drywall/board carrier (SJIII 3219)
- 800W AC inverter
- 250 Ah batteries (cannot be combined with EE rating package)
- AGM Batteries
- EE rating package
- Hinged railing system
- Half height spring hinged gate
- Full height spring hinged gate*
- Bio oil
- Non destructive testing
- ELEVATE telematics package
- Warranty Options (3 year or 5 year plans available)

* Not available with hinged railing system.

† Standard lead times may be increased when optional equipment is added, consult factory.

‡ Capacities and machine weights may differ when options are added.

SJIII 3215/19 ELECTRIC SCISSOR LIFTS

Dimensions	SJIII 3215	SJIII 3219
A Work Height	21' (6.40 m)	25' (7.62 m)
B Raised Platform Height	15' (4.57 m)	19' (5.79 m)
C Lowered Platform Height	34.5" (0.88 m)	39" (0.99 m)
D Overall Width	32" (0.81 m)	32" (0.81 m)
E Overall Length	70" (1.78 m)	70" (1.78 m)
F Stowed Height (Rails Up)	74" (1.88 m)	78.5" (1.99 m)
G Stowed Height (Rails Down)	OPT 60.1" (1.53 m)	OPT 64.5" (1.64 m)
H Platform Width (Inside Dimension)	26" (0.66 m)	26" (0.66 m)
I Platform Length (Inside Dimension)	64" (1.63 m)	64" (1.63 m)
Specifications	SJIII 3215	SJIII 3219
Extension Deck (Roll Out)	3' (0.91 m)	3' (0.91 m)
Ground Clearance (Stowed)	2.375" (6.03 cm)	2.375" (6.03 cm)
Ground Clearance (Raised)	0.7" (1.78 cm)	0.7" (1.78 cm)
Wheelbase	55" (1.40 m)	55" (1.40 m)
Weight	2,400 lbs (1,089 kg)	2,580 lbs (1,170 kg)
Gradeability	30%	30%
Turning Radius (Inside)	0	0
Turning Radius (Outside)	66" (1.68 m)	66" (1.68 m)
Lift Time (With Rated Load)	23 sec	25 sec
Lower time (With Rated Load)	24 sec	29 sec
Drive Speed (Stowed)	2 mph (3.2 km/h)	2 mph (3.2 km/h)
Drive Speed (Raised)	0.7 mph (1.1 km/h)	0.7 mph (1.1 km/h)
Maximum Drive Height	Full Height	Full Height
Capacity (Overall)	600 lbs (272 kg)	550 lbs (249 kg)
Distributed Capacity (Main Platform)	350 lbs (159 kg)	300 lbs (136 kg)
Distributed Capacity (Extension Deck)	250 lbs (113 kg)	250 lbs (113 kg)
Local Floor Load (With Rated Load)	110 psi (759 kPa)	110 psi (759 kPa)
Overall Floor Load (With Rated Load)	200 psf (10 kPa)	201 psf (10 kPa)
Maximum # of Persons	2	2
Wind Rating	28 mph (12.5 m/s)	28 mph (12.5 m/s)
Tire Type	Solid, N/M	Solid, N/M
Tire Size	12 x 4 x 8	12 x 4 x 8

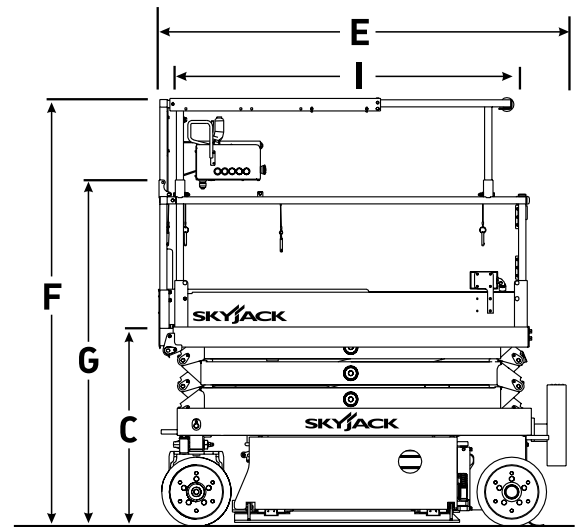
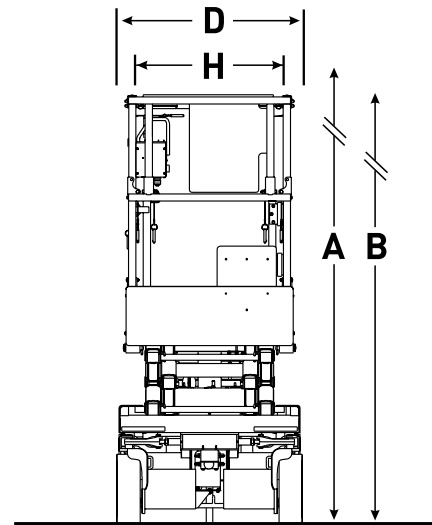

Skyjack Head Office
 55 Campbell Rd. Guelph, ON Canada N1H 1B9
 Sales Inquiries: 1-877-755-4387 (1-877-SJLIFTS)
 Main Switchboard: 1-800-265-2738
 Phone: 519-837-0888
 Fax: 519-837-8104
 Email: skyjack@skyjack.com
 www.skyjack.com

This brochure is for illustrative purpose only and based on the latest information at the time of printing. Skyjack Inc. reserves the right to make changes at any time, without notice, to specifications, standard and optional equipment. Consult the Operating Maintenance and Parts Manuals for proper procedures. Work platforms have been tested to comply with ANSI and CSA standards as interpreted by Skyjack Inc.

