



164 kW (Tier 3a)

168 kW (Tier 4)



120 t



40 m



MAXCAB

6113 E

Telescopic crawler crane

Tier 4f emission standards

6113E Taken further. The E-Series.



1984: S212 telescopic crane

What defines the E-Series

- More than 20 years of experience in designing and manufacturing highly specialized telescopic crawler cranes
- Highest performance in all areas
- Technology that can be handled: high-quality components without complicating them
- Long product lifetime and high residual value



Your most important advantages:

1 Green Efficiency
Save fuel - reduce operating costs
Work quietly - protect operator and environment



2 Power at the highest level
Robust boom system - work up to an incline of 4°
2 equally strong crane winches - high line speeds

3 Maximum usability
Maxcab - work comfortably
SENCON - simple control



4 Flexibility in service
Moving under load - minimal space requirements
Strong undercarriage traction - excellent all-terrain mobility

5 Easy transport
Telescopic undercarriage - ready to go in no time
Ballast unloading system - short setup time

6 Maintenance and service made easy
SENNEBOGEN Control System - easy error diagnostics
Simple maintenance - clear labelling

7 Expertise and support near you
3 production sites - 2 subsidiaries
120 sales partners - more than 300 service points



Emission standards
TIER IV

- Modern, powerful engine
- Fuel-efficient
- Low emissions



6113E Powerful. Effective.

Strong telescopic boom for demanding tasks

- Maintenance-free telescoping thanks to multi-cylinder system
Maintenance-free cable drive or chain drive
- Work on inclines of up to 4° possible*
- Telescoping under load
- Full power boom

Large operating range

- 40.2 m boom length
- Extendable up to 67 m with fly boom and tower extension

Easy and flexible work - saves time

- Precision hydraulics allow telescoping to any boom length quickly
- Intuitive joystick control
- Ready to go in no time, even with varying work heights
- Always the ideal boom length in no time at all

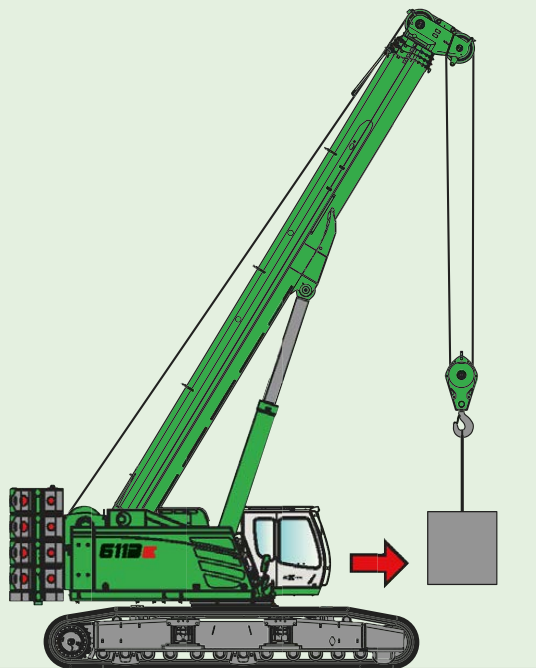

Unique flexibility on the construction site

- Moveable even under high loads
- Excellent maneuverability thanks to strong undercarriage traction
- Easy, inexpensive transport and short set-up time thanks to self-assembly system

Telescopic undercarriage

- Maximum stability due to extremely long, telescopic crawler track with large outrigger area
- Low ground pressure due to wide crawler shoes, wvreliable stability even during dynamic tasks
- Robust tractor chassis and well sized travel drive for maximum all-terrain movement

6113E Modern. Flexible.



Hoisting winches

- Two hoisting winches working side by side
- Compact machine with small rear radius

Elevating work platform*

- Unfolds to an internal size of 4 x 1.25 m
- Payloads up to 1,000 kg possible
- 360° continuous rotation

1,000 kg elevating work platform*



Quiet operation

- Consistently quiet operation thanks to decoupled engine suspension and soundproofing

Clearly arranged engine compartment

- Extremely service-friendly design
- Engine TIER III emission standard
- Engine TIER IVf emission standard incl. AdBlue supply

* Check for availability

6113E Comfort redefined

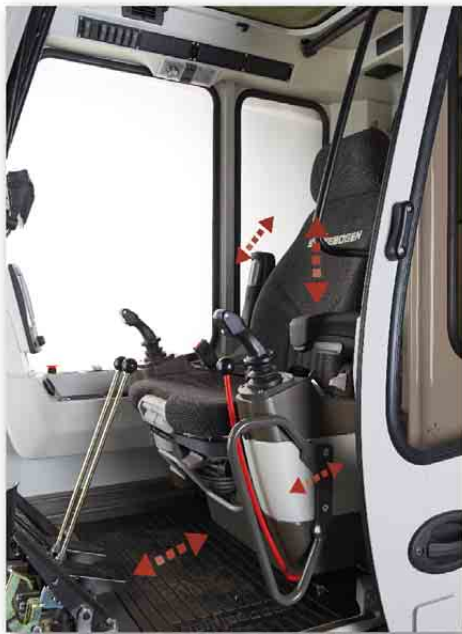

Automatic climate control

- Work climate is always pleasant in the cab, due to 10 uniformly distributed fan outlets
- Central controls for easy operation

Comfortable Maxab operator cab

- Air-suspension comfortable seat with seat heater
- Convenient joystick control
- Hinged front window
- Sliding door, platform in front of cab
- Color monitor for up to 4 cameras
- Cab can be tilted 20°

SENCON control system

- Clear menu control
- Custom fine-tuning, optimal machine performance
- Integrated load moment limiting with capacity utilization indicator
- Fast troubleshooting due to detailed information

6113E Maintenance and service made easy

Simplest service

- Central, easily accessible lubricating strip
- Optional: central lubrication system for automatic lubrication

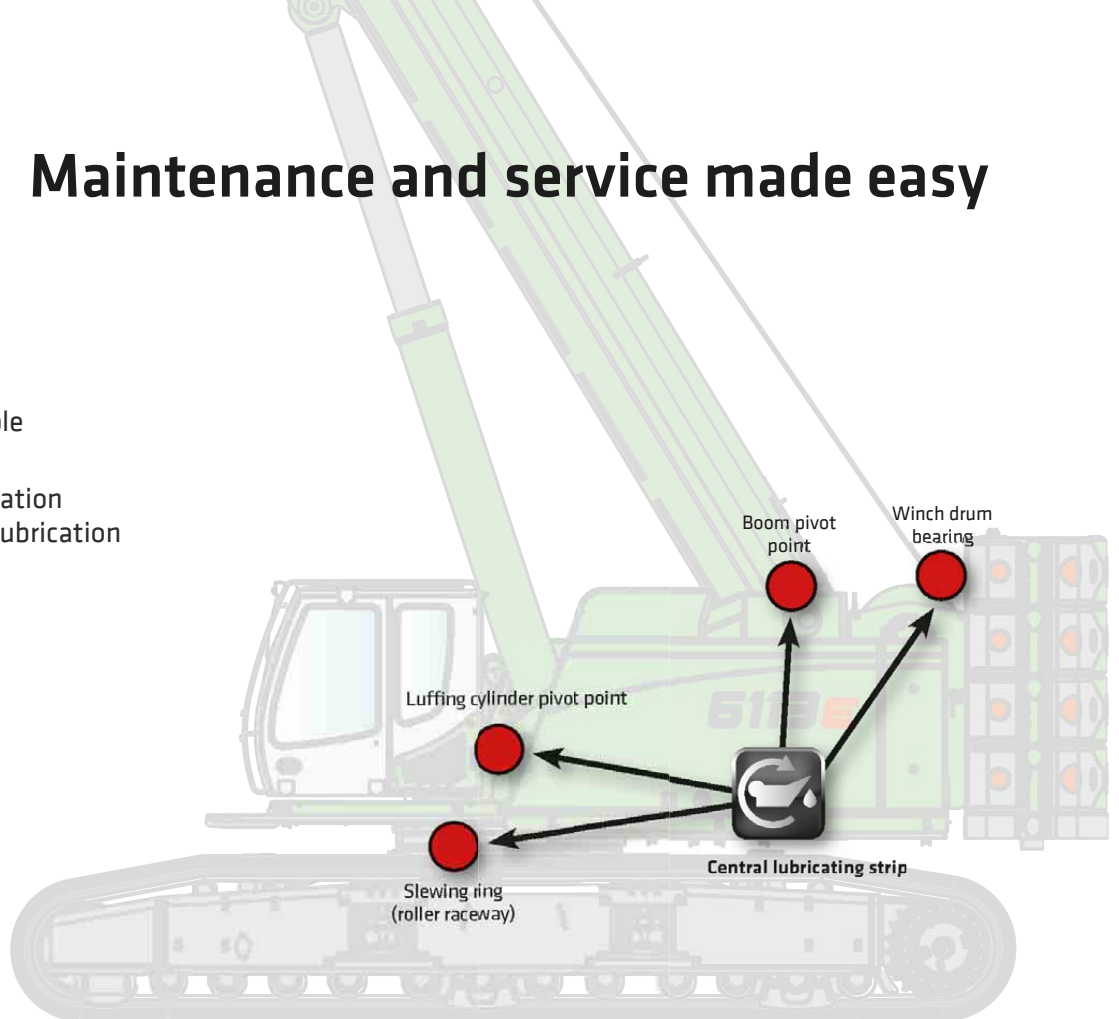

HydroClean*

- Optimal protection of hydraulic components thanks to 3 µm micro-filter
- Cleaner hydraulic oil, extended oil service life
- With water separator



Walkways on both sides

- Step grid in front of and next to cab for more safety while entering and exiting
- Step grids along left and right sides of uppercarriage for safe maintenance



Optimized for maintenance

- Fast and easy troubleshooting thanks to straightforward and clearly labeled electrical distributor
- Easy access to all service points on the machine

* Optional

6113E Technical data - equipment

MACHINE TYPE

Model (type) **6113**

ENGINE

Model	Cummins diesel engine QSB 6.7 164 kW / 223 hp at 2,000 rpm Compliant with TIER III emission standard
	Cummins diesel engine QSB 6.7 168 kW / 228 hp at 2,000 rpm Compliant with TIER IVf emission standard
	Direct injection, turbo-charged, charge air cooling, reduced emissions
Cooling	Water-cooled
Diesel filter	with water separator and heating system
Air filter	Dry filter with integrated pre-separator, automatic dust discharge, main element and safety element, contamination indicator
Fuel tank	540 l
AdBlue tank	38 l
Electrical system	24 V
Batteries	2 x 155 AH battery disconnect switch
Options	<ul style="list-style-type: none"> ■ Low-temperature package with engine pre-heating and heated diesel filter for temperatures below -20 °C ■ Electric fuel pump

UPPERCARRIAGE

Design	Torsion-resistant box design, precision crafted, steel bushings for boom bearings Extremely service-friendly design, longitudinal engine
Electrical	Central electrical distributor, battery disconnect switch
Cooling system	3-circuit cooling system with high cooling capacity, thermostatically regulated fan drive for oil cooler, electronically regulated water and charge air cooler
Safety	Rearview and right sideview cameras LED lighting package Uppercarriage railing
Options	<ul style="list-style-type: none"> ■ Additional LED headlights ■ Up to 2 additional cameras ■ Anti-corrosive maritime climate varnish ■ Low-temperature package for use at temperatures below -20 °C

Options

- Automatic central lubrication for boom pivot point, luffing cylinder, slewing ring track and winch drum bearing
- Pinion tooth lubrication for slewing ring

HYDRAULIC SYSTEM

	Load sensing/LUDV hydraulic system, electrohydraulic pilot-controlled work functions, load limit sensing control
Pump type	Swashplate-type variable-displacement piston pump, load pressure-independent flow distribution for simultaneous, independent control of work functions
Pump control	Zero-stroke control, on-demand flow control - the pumps only pump as much oil as will actually be used, pressure purging, load limit sensing control
Operating pressure	Max. 330 bar
Filtration	High-performance filtration with long change interval
Hydraulic tank	1,125 l
Control system	Proportional, precision electrohydraulic actuation of work movements, 2 electric servo joysticks for work functions, including winch motion display via vibration transducer, additional functions via switches and pedals
Safety	Hydraulic circuits with safety valves Pipe fracture safety valve for luffing and telescoping cylinders
Options	<ul style="list-style-type: none"> ■ Bio-oil - ecologically worthwhile ■ SENNEBOGEN HydroClean 3 µm hydraulic microfilter ■ Electric heater for hydraulic tank for temperatures below -20 °C

SLEWING DRIVE

Gearbox	2x compact planetary gear with slant axis hydraulic motor, integrated brake valves
Slewing brake	Spring-loaded disk brake, pedal for individual braking
Slewing ring	Externally geared slewing ring, sealed
Slewing speed	0-2 rpm , continuous

6113E Technical data - equipment

CAB MAX CAB

Cab type	Maxcab full-size cab, tiltable up to 20°
Cab equipment	Sliding door, excellent ergonomics, automatic climate control, heated seat, air-suspension comfort seat, fresh air filter/circulating air filter, 12 V/24 V connections, SENCON, sunblind for roof window
Options	<ul style="list-style-type: none"> ■ Hydraulically elevating cab E270, can be elevated up to 2.70 m and tilted up to 30° ■ Auxiliary heating system with timer ■ Carbon-active filter for cab ■ Sliding window in operator door ■ Armored glass windshield ■ Armored glass roof window ■ Protective roof grating ■ FOPS protective roof grating ■ Radio with CD player

ATTACHMENTS

Design	Decades of experience, state-of-the-art computer simulation, maximum stability, longest service life, oversized, low-maintenance bearing points, sealed special bearing bushes, precision-crafted
Telescopic boom	4-piece with roller head, continuous hydraulic telescoping from 12.6 – 40.2 m
Hoisting winch	Slant-axis hydraulic motor drive with compact planetary gear, 125 kN pulling power, 0 – 115 m/min. winching speed, 26 mm cable diameter, 175 m cable length. Winch motion display via vibration transducers in the joysticks
Safety brake	Spring-loaded disk brake
Crane safety	Latest generation of load moment monitoring, clearly organized panel displaying all important data via SENCON display, lifting limit switch, cable exit protection, pressure relief valves and pipe fracture safety device with event recorder
Cylinders	Hydraulic cylinders with high-quality sealing and guide elements
Options	<ul style="list-style-type: none"> ■ 8-m fly jib, tiltable (0°, 20°, 40°), extremely fast and easy setup without auxiliary devices, locked on basic boom when not in use ■ Fly jib extension to 15 m (7 m extension), tiltable (0°, 20°, 40°), must be transported separately

Options	<ul style="list-style-type: none"> ■ Auxiliary jib, 12-t load capacity, 1-strand ■ 2nd crane winch with 125 kN pulling power, 0–115 m/min. cable speed, 26 mm cable diameter, 175 m cable length ■ Additional load charts accepted for 2°/4° incline position ■ Suitable for use as elevating work platform with up to 4 m width and 1,000 kg payload ■ 3 kW electrohydraulic emergency unit ■ Remote radio control
---------	---

UNDERCARRIAGE

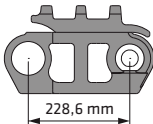
Design	T119/540 crawler undercarriage with hydraulically extendable track gauge. Stable welded construction
Drive	Hydraulic travel drive per chassis side, hydraulic traction motors
Parking brake	Spring-loaded, hydraulically ventilated disk brake
Traveling gear	900 mm triple bar shoes, maintenance-free tractor chassis 
Speed	0 – 2.5 kph
Options	900-mm flat crawler shoes

OPERATING WEIGHT

Mass	Approx. 112,200 kg With 40.2-m telescopic boom, 8-m fly jib, 80 t hook, 900-mm triple-bar-shoes, 2 hoisting winches with hydraulically telescoping undercarriage, 33 t ballast
Note	Operating weight varies by model.

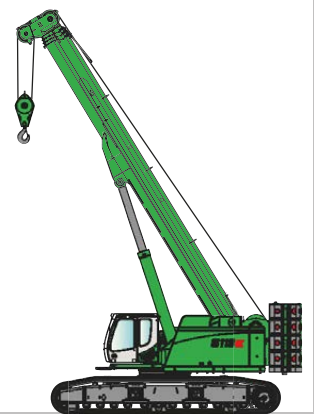

6113E Crane equipment



40.2-m main boom (HA)

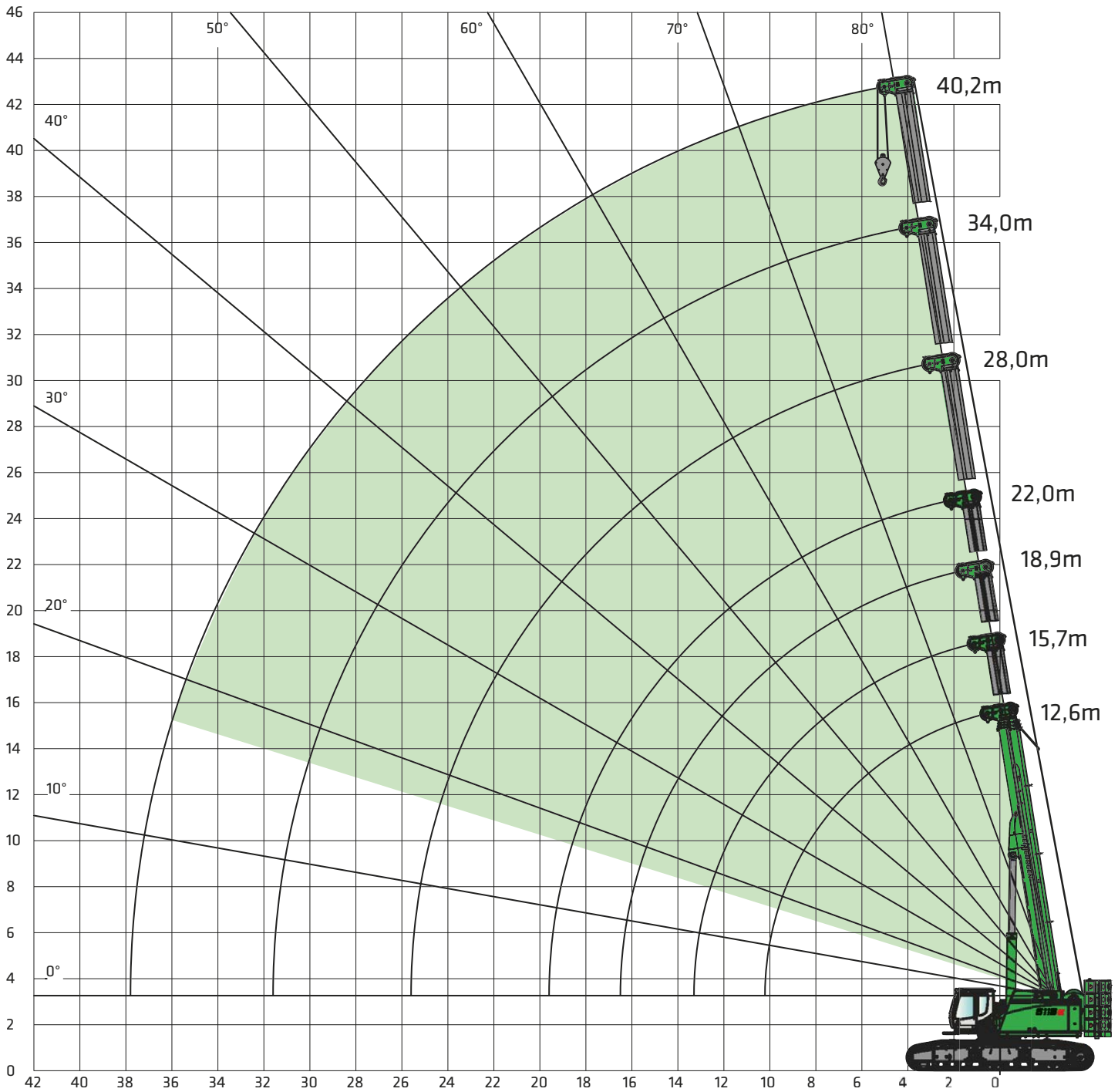

10 Subject to change. See page 21 for notes on load charts.

6113E Load ratings



0.2-m main boom (HA)

	Boom length [m]																				
	12.6			15.7			18.9			22.0			28.0			34.0			40.2		
Counterweight [t]																					
Carbody counterweight [t]																					
Undercarriage track width [m]																					
Working radius [m]																					
2.5	120.0																				
3.0	100.0																				
4.0	84.0	75.0	75.0	69.0	69.0	69.0	66.0	66.0	66.0	52.0	52.0	52.0									
5.0	75.0	75.0	75.0	69.0	69.0	69.0	61.4	61.4	61.4	52.0	52.0	52.0	37.0	37.0	37.0	30.0	30.0	30.0			
6.0	70.0	70.0	63.5	67.0	67.0	63.1	54.0	54.0	54.0	48.4	48.2	48.2	37.0	37.0	37.0	29.8	29.8	29.8	21.0	21.0	21.0
7.0	60.0	55.5	53.7	59.0	54.9	53.3	48.3	48.3	48.3	43.3	43.3	43.3	36.2	36.2	36.2	28.5	28.5	28.5	21.0	21.0	21.0
8.0	52.0	45.1	46.0	50.0	44.5	45.4	43.4	43.4	43.4	38.8	38.8	38.8	33.7	33.7	33.7	27.0	27.0	27.0	20.0	20.0	20.0
9.0	45.0	37.7	37.8	45.0	37.2	37.2	39.3	36.8	36.8	35.2	35.2	35.2	31.0	31.0	31.0	25.2	25.2	25.2	19.4	19.4	19.4
10.0	40.0	32.1	31.8	39.9	31.7	31.3	36.0	31.3	30.9	32.1	31.0	30.6	28.2	28.2	28.2	23.4	23.4	23.4	18.6	18.6	18.6
12.0				30.8	24.0	23.2	30.5	23.7	22.9	27.1	23.5	22.6	24.4	24.3	23.6	20.4	20.4	20.4	16.6	16.6	16.6
14.0							23.9	18.6	17.7	23.2	18.4	17.4	21.1	19.2	18.3	17.9	17.9	17.9	14.8	14.8	14.8
16.0							19.3	15.0	14.0	19.1	14.8	13.8	18.4	15.6	14.7	15.9	15.9	15.2	13.3	13.3	13.3
18.0										15.7	12.1	11.1	16.2	12.9	12.0	14.3	13.4	12.5	12.0	12.0	12.0
20.0													14.0	10.8	9.9	12.9	11.3	10.4	10.8	10.8	10.8
22.0													12.0	9.1	8.3	11.6	9.6	8.8	9.8	9.8	9.1
24.0													10.3	7.7	6.8	10.7	8.2	7.4	9.0	8.6	7.8
26.0																9.4	7.1	6.2	8.2	7.4	6.6
28.0																8.2	6.0	5.2	7.6	6.4	5.6
30.0																7.2	5.1	4.4	7.0	5.5	4.8
32.0																			6.4	4.7	4.0
34.0	Table no.: 6113R-75/2790/33.0+0.0/09.14 HA 0.3*																		5.7	4.0	3.3
36.0	Table no.: 6113R-75/2190/33.0+0.0/09.14 HA 0.3*																		5.1	3.4	2.8
Parts reeving	10	6	6	8	8	8	8	8	8	7	7	7	5	5	5	4	4	4	3	3	3
I	0%		33%			66%			100%			100%			100%						
II	0%		0%			0%			0%			33%			66%						
III	0%		0%			0%			0%			33%			66%						
Load ratings must be reduced when fly jib is mounted on basic body.																					
Reduction of load [kg]	520			420			350			300			240			200			170		

6113E Load ratings



Auxiliary jib (HA-S)

	Boom length [m]																				
	12.6			15.7			18.9			22.0			28.0			34.0			40.2		
Counterweight [t]																					
Carbody counterweight [t]																					
Undercarriage track width [m]																					
Working radius [m]																					
2.5																					
3.0	12.5	12.5	12.5	12.5	12.5	12.5															
4.0	12.5	12.5	12.5	12.5	12.5	12.5	12.5	12.5	12.5	12.5	12.5	12.5									
5.0	12.5	12.5	12.5	12.5	12.5	12.5	12.5	12.5	12.5	12.5	12.5	12.5	12.5	12.5	12.5	12.5	12.5	12.5			
6.0	12.5	12.5	12.5	12.5	12.5	12.5	12.5	12.5	12.5	12.5	12.5	12.5	12.5	12.5	12.5	12.3	12.3	12.3			11.9
7.0	12.5	12.5	12.5	12.5	12.5	12.5	12.5	12.5	12.5	12.5	12.5	12.5	12.5	12.5	12.5	12.2	12.2	12.2	11.8	11.8	11.8
8.0	12.5	12.5	12.5	12.5	12.5	12.5	12.5	12.5	12.5	12.5	12.5	12.5	12.5	12.5	12.5	12.1	12.1	12.1	11.7	11.7	11.7
9.0	12.5	12.5	12.5	12.5	12.5	12.5	12.5	12.5	12.5	12.5	12.5	12.5	12.4	12.4	12.4	12.0	12.0	12.0	11.5	11.5	11.5
10.0	12.5	12.5	12.5	12.5	12.5	12.5	12.5	12.5	12.5	12.5	12.5	12.5	12.3	12.3	12.3	11.9	11.9	11.9	11.4	11.4	11.4
12.0				12.5	12.5	12.5	12.5	12.5	12.5	12.5	12.5	12.5	12.3	12.3	12.3	11.8	11.8	11.8	11.3	11.3	11.3
14.0							12.5	12.5	12.5	12.5	12.5	12.5	12.3	12.3	12.3	11.8	11.8	11.8	11.1	11.1	11.1
16.0							12.5	12.5	12.5	12.5	12.5	12.5	12.3	12.3	12.3	11.7	11.7	11.7	10.8	10.8	10.8
18.0										12.5	12.4	11.5	12.3	12.3	12.2	11.7	11.7	11.7	10.3	10.3	10.3
20.0													12.3	11.0	10.1	11.5	11.5	10.6	9.5	9.5	9.5
22.0													12.1	9.3	8.4	10.6	9.8	8.9	8.7	8.7	8.7
24.0													10.4	7.9	7.0	9.8	8.4	7.6	8.0	8.0	7.9
26.0																9.0	7.2	6.4	7.4	7.4	6.7
28.0																8.3	6.1	5.3	6.9	6.5	5.7
30.0																7.2	5.2	4.4	6.4	5.6	4.8
32.0																			5.9	4.8	4.1
34.0	Table no.: 6113R-75/2790/33.0+0.0/09.14 HA-S 0.3°																		5.5	4.1	3.4
36.0	Table no.: 6113R-75/2190/33.0+0.0/09.14 HA-S 0.3°																		5.1	3.4	2.8
Parts reeving	1	1	1	1	1	1	1	1	1	1	1	1	1	1	1	1	1	1	1	1	1
I	0%			33%			66%			100%			100%			100%					
II	0%			0%			0%			0%			33%			66%					
III	0%			0%			0%			0%			33%			66%					
Load ratings must be reduced when fly jib is mounted on basic body.																					
Reduction of load [kg]	770			610			510			430			340			280			240		

6113E Crane equipment



8-m or 15-m fly jib (SA)

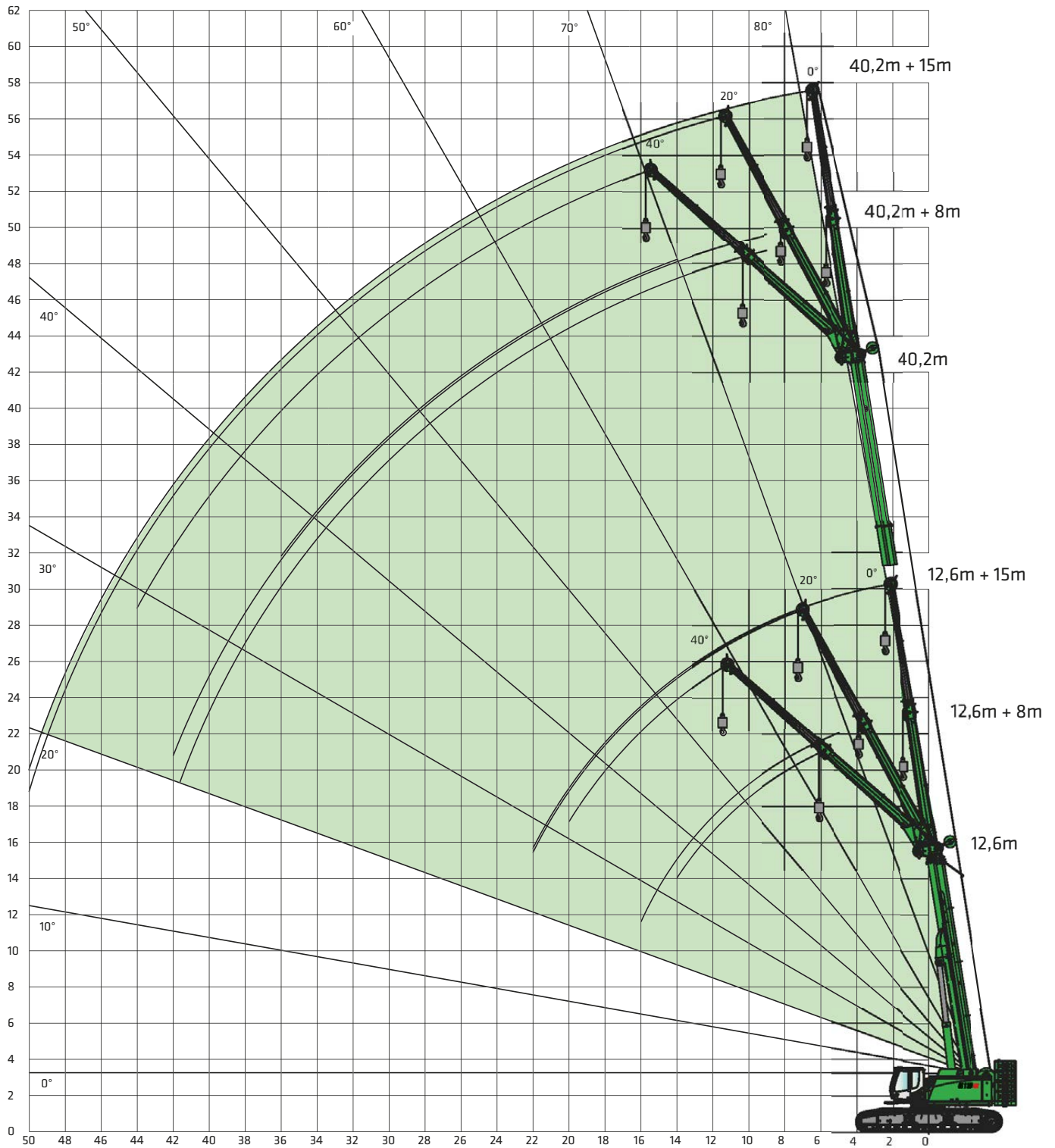

6113E Load ratings



8-m fly jib (SA)

33.0 t	0 t	Telescopic boom length [m]														
		12.6			22.0			28.0			34.2			40.2		
5.4 m	0°	20°	40°	0°	20°	40°	0°	20°	40°	0°	20°	40°	0°	20°	40°	
Working radius [m]																
5.0	15.4	10.9		18.0			17.5									
6.0	14.0	10.2	8.1	16.5			16.5									
7.0	12.8	9.7	7.8	15.5	10.5		15.6	10.3		14.2						
8.0	11.8	9.2	7.5	14.5	10.1	7.8	14.7	10.1		13.7						
9.0	10.9	8.7	7.2	13.6	9.7	7.6	14.0	9.8	7.6	13.1	9.5		11.8			
10.0	10.2	8.3	6.9	12.8	9.3	7.4	13.3	9.5	7.4	12.6	9.3	7.3	11.4			
12.0	9.0	7.5	6.4	11.5	8.7	7.0	12.1	8.9	7.1	11.7	8.8	7.0	10.8	8.4		
14.0	8.0	7.1	6.1	10.4	8.2	6.6	11.0	8.4	6.7	10.9	8.3	6.7	10.2	8.0	6.5	
16.0	7.2	6.7		9.5	7.7	6.3	10.2	8.0	6.5	10.2	8.0	6.4	9.6	7.7	6.3	
18.0				8.7	7.3	6.1	9.5	7.6	6.3	9.5	7.6	6.2	9.1	7.4	6.1	
20.0				8.1	7.0	5.9	8.8	7.3	6.0	9.0	7.3	6.0	8.5	7.1	5.9	
22.0				7.5	6.7		8.2	7.0	5.8	8.4	7.0	5.8	8.0	6.9	5.8	
24.0				7.0	6.5		7.7	6.7	5.7	8.0	6.8	5.7	7.4	6.6	5.6	
26.0							7.3	6.5	5.6	7.5	6.6	5.5	6.8	6.4	5.5	
28.0							6.9	6.4		7.2	6.4	5.4	6.3	6.2	5.3	
30.0							6.6	6.2		6.8	6.2	5.3	5.8	5.8	5.2	
32.0							6.4			6.5	6.1		5.4	5.5	5.2	
34.0										5.9	6.0		5.0	5.1	5.1	
36.0										5.2	5.4		4.7	4.7	4.8	
38.0										4.6			4.3	4.4		
40.0													4.0	4.1		
42.0													3.6	3.7		
44.0													3.2			
46.0																
48.0																
50.0																
52.0																
54.0	Table no.: 6113R-75/2790/33.0+0.0/09.14 SA8 0.3*															
Parts reeving	2	2	1	2	2	1	2	2	1	2	2	1	2	2	1	
I	0%			100%			100%			100%			100%			
II	0%			0%			33%			66%			100%			
III	0%			0%			33%			66%			100%			

6113E Load ratings



15 m fly jib (SA)

33.0 t	0 t	Telescopic boom length [m]														
		12.6			22.0			28.0			34.2			40.2		
5.4 m	0°	20°	40°	0°	20°	40°	0°	20°	40°	0°	20°	40°	0°	20°	40°	
Working radius [m]																
5.0	6.0			6.0												
6.0	5.8			5.8			5.8			5.3						
7.0	5.6			5.7			5.6			5.2						
8.0	5.4			5.6			5.4			5.1			4.7			
9.0	5.1	4.1		5.5			5.3			5.0			4.7			
10.0	4.8	4.0		5.3	4.0		5.2			4.9			4.6			
12.0	4.4	3.6	3.1	5.0	3.9		5.0	4.0		4.8			4.5			
14.0	4.0	3.4	2.9	4.7	3.7	3.1	4.8	3.8	3.1	4.6	3.8		4.3			
16.0	3.6	3.2	2.8	4.3	3.5	3.0	4.6	3.6	3.0	4.4	3.6	3.0	4.2	3.5		
18.0	3.3	3.0	2.7	4.0	3.3	2.9	4.3	3.4	2.9	4.3	3.4	2.9	4.1	3.4	2.8	
20.0	3.1	2.8	2.6	3.7	3.2	2.8	4.0	3.3	2.8	4.1	3.3	2.8	4.0	3.2	2.7	
22.0	2.9	2.7		3.5	3.0	2.7	3.8	3.1	2.7	3.9	3.2	2.7	3.8	3.1	2.6	
24.0				3.3	2.9	2.6	3.6	3.0	2.7	3.7	3.1	2.7	3.7	3.0	2.5	
26.0				3.1	2.8	2.6	3.4	2.9	2.6	3.5	2.9	2.6	3.5	2.9	2.5	
28.0				2.9	2.7	2.5	3.2	2.8	2.5	3.3	2.9	2.5	3.4	2.8	2.5	
30.0				2.8	2.6		3.1	2.7	2.5	3.2	2.8	2.5	3.2	2.7	2.5	
32.0							2.9	2.7	2.4	3.1	2.7	2.4	3.1	2.7	2.4	
34.0							2.8	2.6		2.9	2.6	2.4	3.0	2.6	2.4	
36.0							2.7	2.6		2.8	2.6	2.4	2.9	2.6	2.3	
38.0							2.6	2.5		2.7	2.5	2.3	2.8	2.5	2.3	
40.0										2.6	2.5		2.7	2.5	2.3	
42.0										2.5	2.5		2.6	2.4	2.2	
44.0													2.5	2.4	2.2	
46.0													2.4	2.4		
48.0													2.4	2.4		
50.0													2.4	2.4		
52.0																
54.0	Table no.: 6113R-75/2790/33.0+0.0/09.14 SA15 0.3*															
Parts reeving	2	2	1	2	2	1	2	2	1	2	2	1	2	2	1	
I	0%			100%			100%			100%			100%			
II	0%			0%			33%			66%			100%			
III	0%			0%			33%			66%			100%			

6113E Crane equipment



Main boom with 12-m main boom extension (HAV)

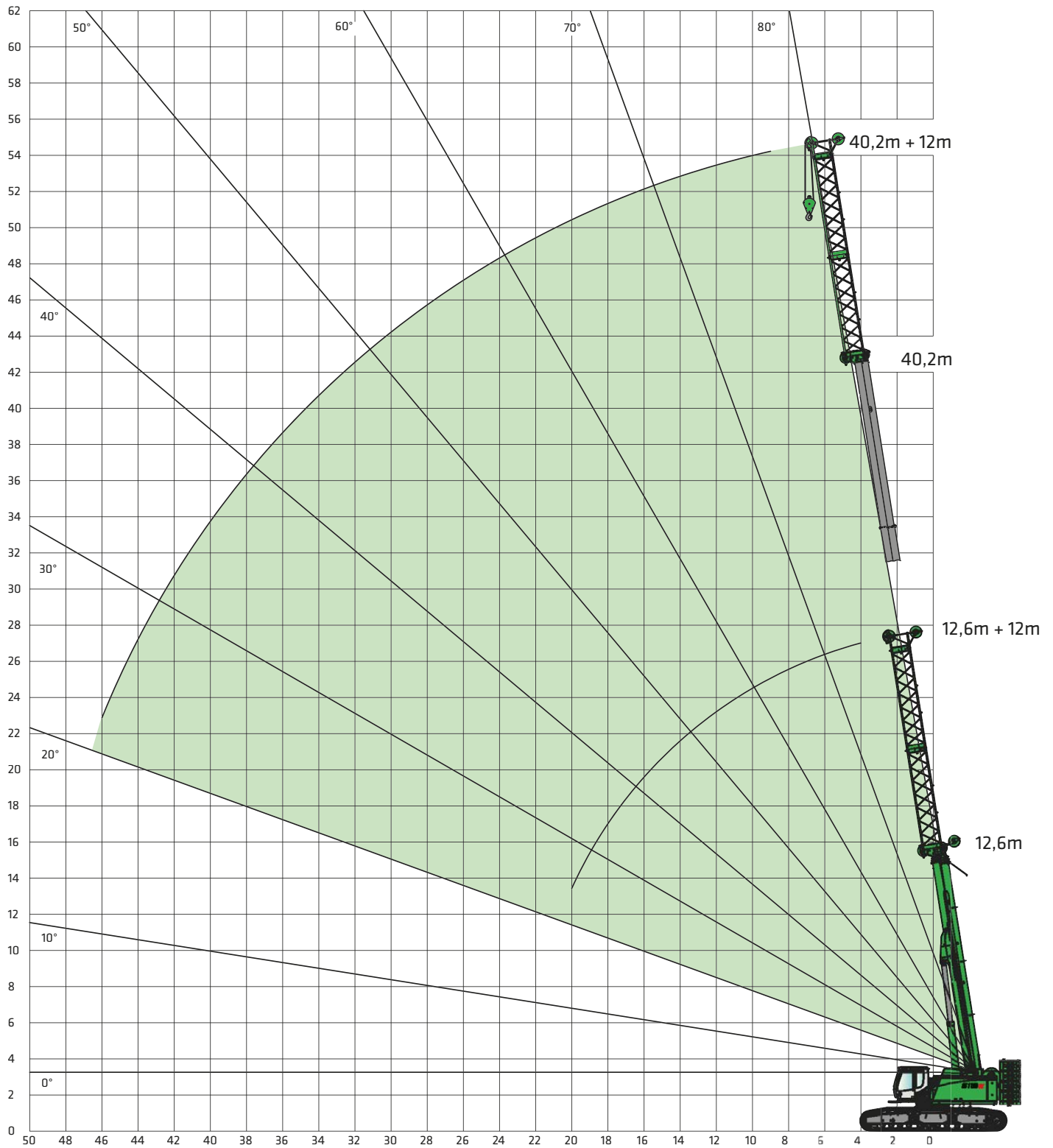

6113E Load ratings



Main boom with 12-m main boom extension (HAV)

33.0 t		0 t		Boom length [m]	
5.4 m					
Working radius [m]	24.6	34.0	40.0	46.2	52.2
4.0	18.7	19.7			
5.0	16.9	18.3			
6.0	15.3	17.0	16.3		
7.0	14.0	15.7	15.4	13.7	
8.0	12.9	14.8	14.6	13.2	
9.0	12.0	13.9	13.7	12.7	11.1
10.0	11.1	13.0	13.1	12.2	10.8
12.0	9.8	11.7	11.9	11.3	10.2
14.0	8.7	10.6	11.0	10.5	9.6
16.0	7.8	9.6	10.1	9.8	9.1
18.0	7.1	8.9	9.4	9.3	8.5
20.0	6.5	8.2	8.7	8.7	7.9
22.0		7.6	8.1	8.2	7.3
24.0		7.1	7.6	7.8	6.7
26.0		6.6	7.2	7.4	6.2
28.0		6.3	6.8	6.8	5.7
30.0			6.5	6.3	5.3
32.0			6.2	5.8	4.9
34.0			5.9	5.4	4.5
36.0				5.0	4.2
38.0				4.7	3.9
40.0				4.2	3.6
42.0					3.3
44.0					3.0
46.0	Table no.: 6113R-75/2790/33.0+0.0/09.14 HAV12				2.8
Parts reeving	2	2	2	2	2
I	0%	100%	100%	100%	100%
II	0%	0%	33%	66%	100%
III	0%	0%	33%	66%	100%
Load ratings must be reduced when fly jib is mounted on basic body.					
Reduction of load [kg]	520	300	240	200	170

6113E Crane equipment



15-m fly jib (SA) with 12-m-main boom extension (HAV)

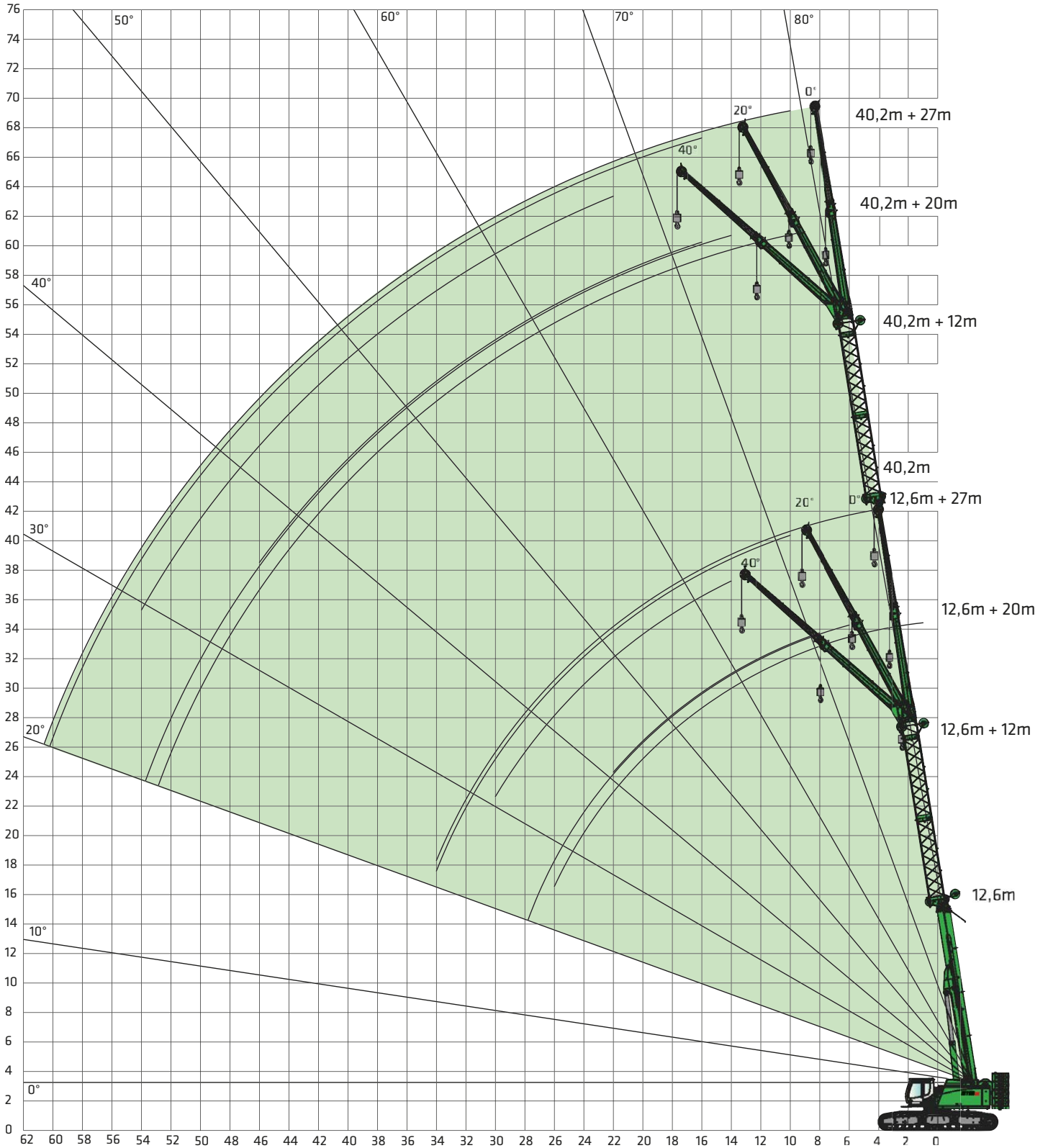

18 Subject to change. See page 21 for notes on load charts.

6113E Load ratings



15-m fly jib (SA) with 12-m-main boom extension (HAV)

33.0 t	0 t	Telescopic boom length [m]														
		12.6			22.0			28.0			34.2			40.2		
5.4 m	12 + 15			12 + 15			12 + 15			12 + 15			12 + 15			
	0°	20°	40°	0°	20°	40°	0°	20°	40°	0°	20°	40°	0°	20°	40°	
Working radius [m]																
4.0	5.0															
5.0	5.0															
6.0	5.0			4.5												
7.0	5.0			4.5			4.3									
8.0	5.0			4.5			4.3									
9.0	5.0			4.5			4.3			3.8						
10.0	4.9	3.2		4.5			4.3			3.8			2.5			
12.0	4.7	3.2		4.5	3.1		4.3			3.8			2.5			
14.0	4.5	3.2	2.6	4.5	3.1		4.2	3.0		3.8	2.9		2.5			
16.0	4.3	3.2	2.6	4.3	3.1	2.5	4.1	3.0		3.8	2.9		2.5	2.5		
18.0	4.0	3.2	2.6	4.2	3.1	2.5	4.0	3.0	2.5	3.7	2.9		2.5	2.5		
20.0	3.6	3.0	2.6	4.0	3.1	2.5	3.9	3.0	2.5	3.6	2.9	2.6	2.5	2.5		
22.0	3.3	2.9	2.6	3.8	3.1	2.5	3.7	3.0	2.5	3.5	2.9	2.5	2.5	2.5	2.4	
24.0	3.1	2.8	2.5	3.6	3.0	2.5	3.6	3.0	2.5	3.4	2.9	2.4	2.5	2.5	2.3	
26.0	2.8	2.6	2.4	3.3	2.8	2.5	3.4	2.9	2.5	3.3	2.8	2.4	2.5	2.5	2.3	
28.0	2.6	2.4	2.4	3.1	2.7	2.4	3.2	2.8	2.4	3.1	2.8	2.4	2.5	2.5	2.3	
30.0	2.4	2.3	2.3	2.9	2.6	2.4	3.0	2.7	2.3	3.0	2.7	2.3	2.5	2.5	2.2	
32.0	2.2	2.1		2.7	2.5	2.3	2.8	2.6	2.3	2.9	2.6	2.3	2.5	2.5	2.2	
34.0	2.1	2.0		2.6	2.3	2.3	2.6	2.5	2.3	2.7	2.5	2.2	2.5	2.5	2.1	
36.0				2.4	2.2	2.2	2.5	2.4	2.3	2.6	2.4	2.2	2.5	2.4	2.1	
38.0				2.3	2.1	2.1	2.4	2.2	2.2	2.5	2.3	2.1	2.5	2.3	2.1	
40.0				2.1	2.0		2.2	2.1	2.1	2.3	2.2	2.1	2.4	2.3	2.1	
42.0				2.0	1.9		2.1	2.0	2.0	2.2	2.1	2.1	2.3	2.2	2.0	
44.0					1.8		2.0	2.0		2.1	2.0	2.0	2.2	2.1	2.0	
46.0							1.9	1.9		2.0	2.0	2.0	2.1	2.0	2.0	
48.0							1.8	1.8		1.9	1.9	1.9	2.0	2.0	2.0	
50.0								1.7		1.9	1.8		1.8	1.9	1.9	
52.0										1.8	1.8		1.7	1.8	1.8	
54.0										1.7	1.7		1.5	1.6	1.7	
56.0											1.7		1.4	1.5		
58.0													1.2	1.3		
60.0													1.1	1.2		
62.0													0.9	1.0		
64.0	Table no.: 6113R-75/2790/33.0+0.0/09.14 HAV12 + SA15															
Parts reeving	2	2	2	2	2	2	2	2	2	2	2	2	2	2	2	
I	0%			100%			100%			100%			100%			
II	0%			0%			33%			66%			100%			
III	0%			0%			33%			66%			100%			

6113E Crane equipment





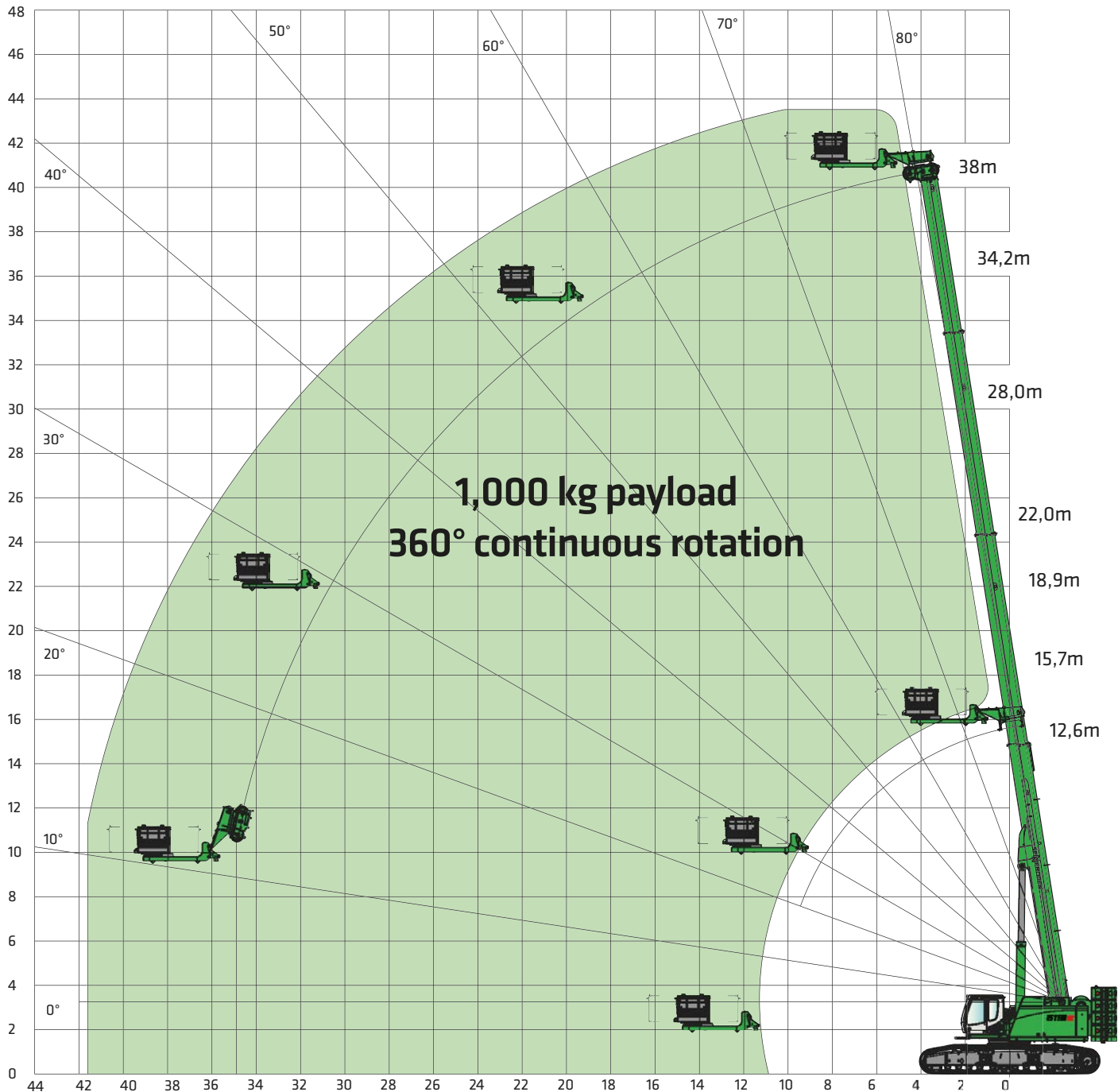





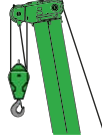
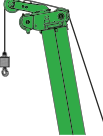













































Elevating work platform type 4000/1000



20 Subject to change. See page 21 for notes on load lift charts.

6113E Load capacity programs

	Main boom (HA)			Auxiliary jib (HA-S)			12-m main boom extension (HAV)		
									
Undercarriage track width	 5.4 m	 4.2 m	 3.05 m	 5.4 m	 4.2 m	 3.05 m	 5.4 m	 4.2 m	 3.05 m
Counterweight [t]									
 33 t	 360°	 360°	-	 360°	 360°	-	 360°	-	-
 19.2 t	 360°	 360°	 360°	 360°	 360°	 360°	-	-	-
 0 t	 360°	 360°	 360°	 360°	 360°	 360°	-	-	-

	8-m fly jib (SA)			15-m fly jib (SA)			12-m main boom extension (HAV) + 8-m fly jib (SA)			12-m main boom extension (HAV) + 15-m fly jib (SA)		
												
Undercarriage track width	 5.4 m	 4.2 m	 3.05 m	 5.4 m	 4.2 m	 3.05 m	 5.4 m	 4.2 m	 3.05 m	 5.4 m	 4.2 m	 3.05 m
Counterweight [t]												
 33 t	 360°	-	-	 360°	-	-	 360°	-	-	 360°	-	-
 19.2 t	-	-	-	-	-	-	-	-	-	-	-	-
 0 t	-	-	-	-	-	-	-	-	-	-	-	-

Note:

Optional lift capacities available for 2° and 4° incline positions.

1. Specified load ratings only apply when machine is level ($\pm 0.3^\circ$) and stable.
2. Load ratings are in tons (t) and apply for 360 degrees.
3. Load ratings are in accordance with EN 13000.
4. The weight of the load handling devices (e.g., hook, cable) must be subtracted from the load ratings.
5. Load ratings must be limited or reduced when conditions are unfavorable, such as soft or uneven ground, slopes, wind, lateral loads, swinging loads, jerking or sudden stopping of load, operator inexperience, driving with load.
6. Permissible cable pull per strand in crane mode for cable diameter 26 mm - 12,500 kg.
7. Specified load ratings are for reference only. See the tables in the operating manual for the applicable load rating.

6113E Transport dimensions and weights

Weight: approx. 112.2 t (2 winches, 8 m fly jib, 80 t hook, 33 t counterweight, 900 mm 3-grouser crawler shoes)
 Transport width: 4 m

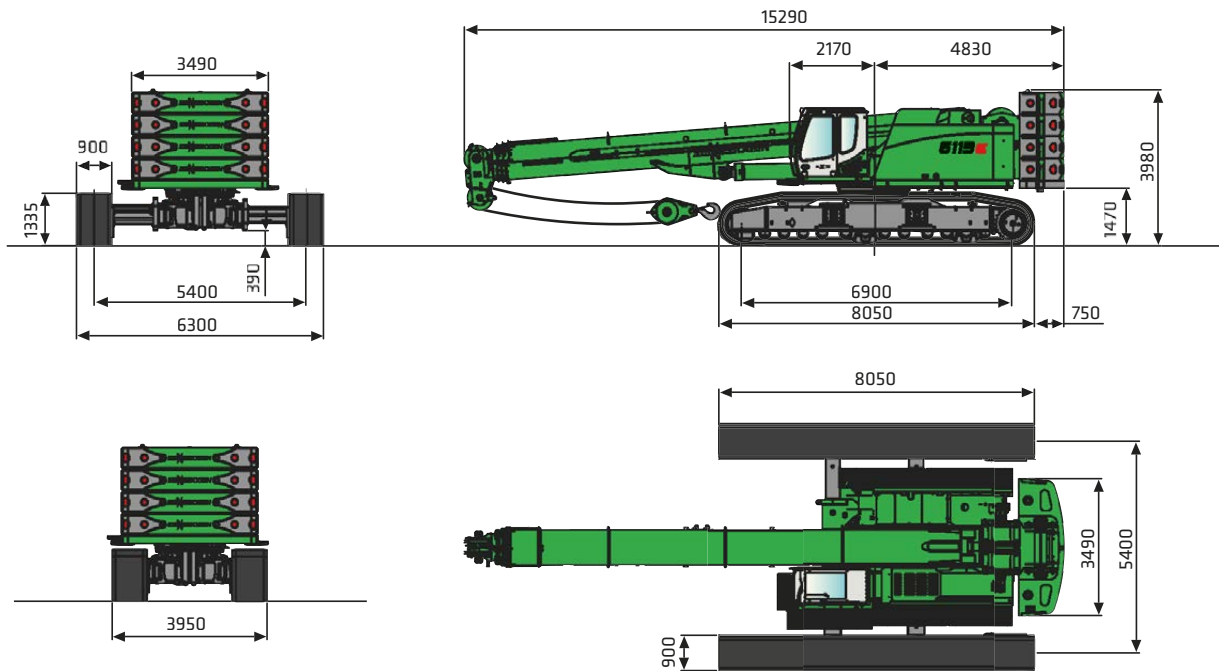

Weight: approx. 78.8 t (2 winches, 8 m fly jib, 80 t hook, no counterweight, 900-mm triple-bar-shoes)
 Transport width: 4 m

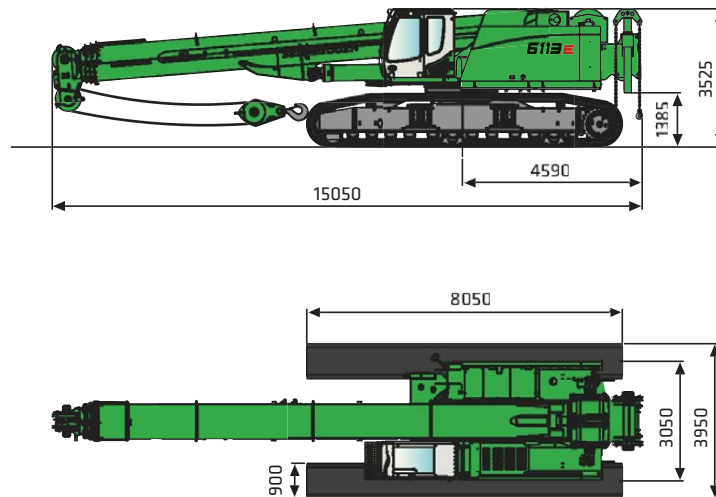

Weight: approx. 47.7 t (2 winches, 8 m fly jib, 80 t hook)
 Transport width: 3 m

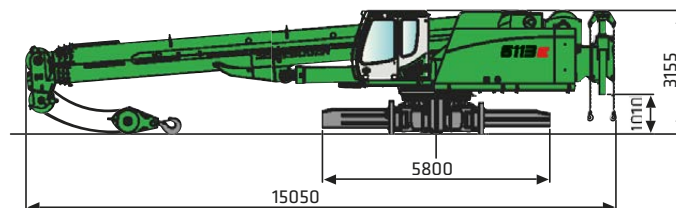

6113E Transport dimensions and weights

	Track wheel carrier	2x	15,700 kg
	Base plate for counterweight	1x	5,400 kg
	Counterweight	4x	6,980 kg
	8 m fly jib		900 kg
	7 m fly jib extension		300 kg
	Auxiliary jib		160 kg
	Work platform incl. adapter		2,460 kg
	Boom section		573 kg
	Head piece		391 kg

6113E Self-assembly system

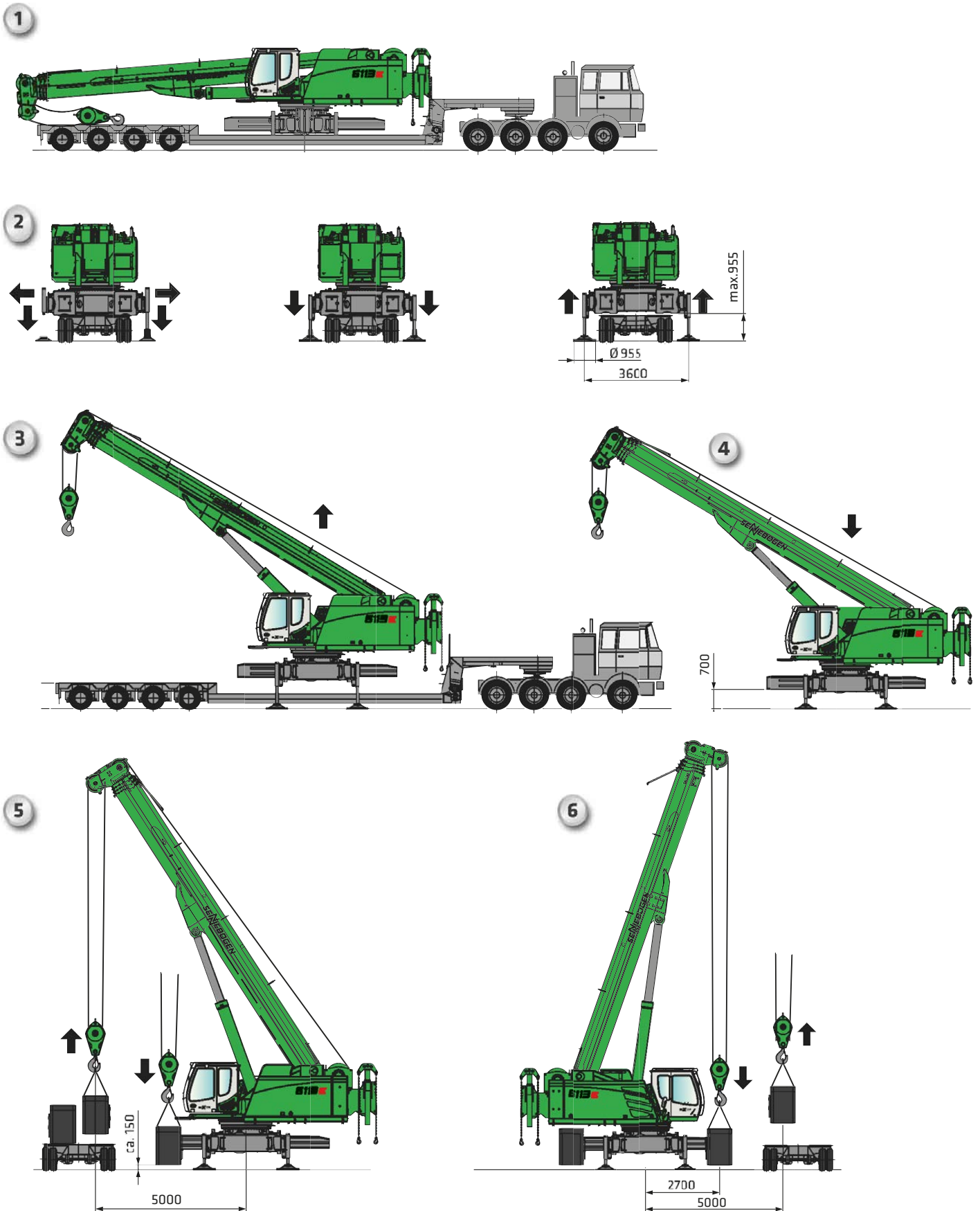

6113E Self-assembly system

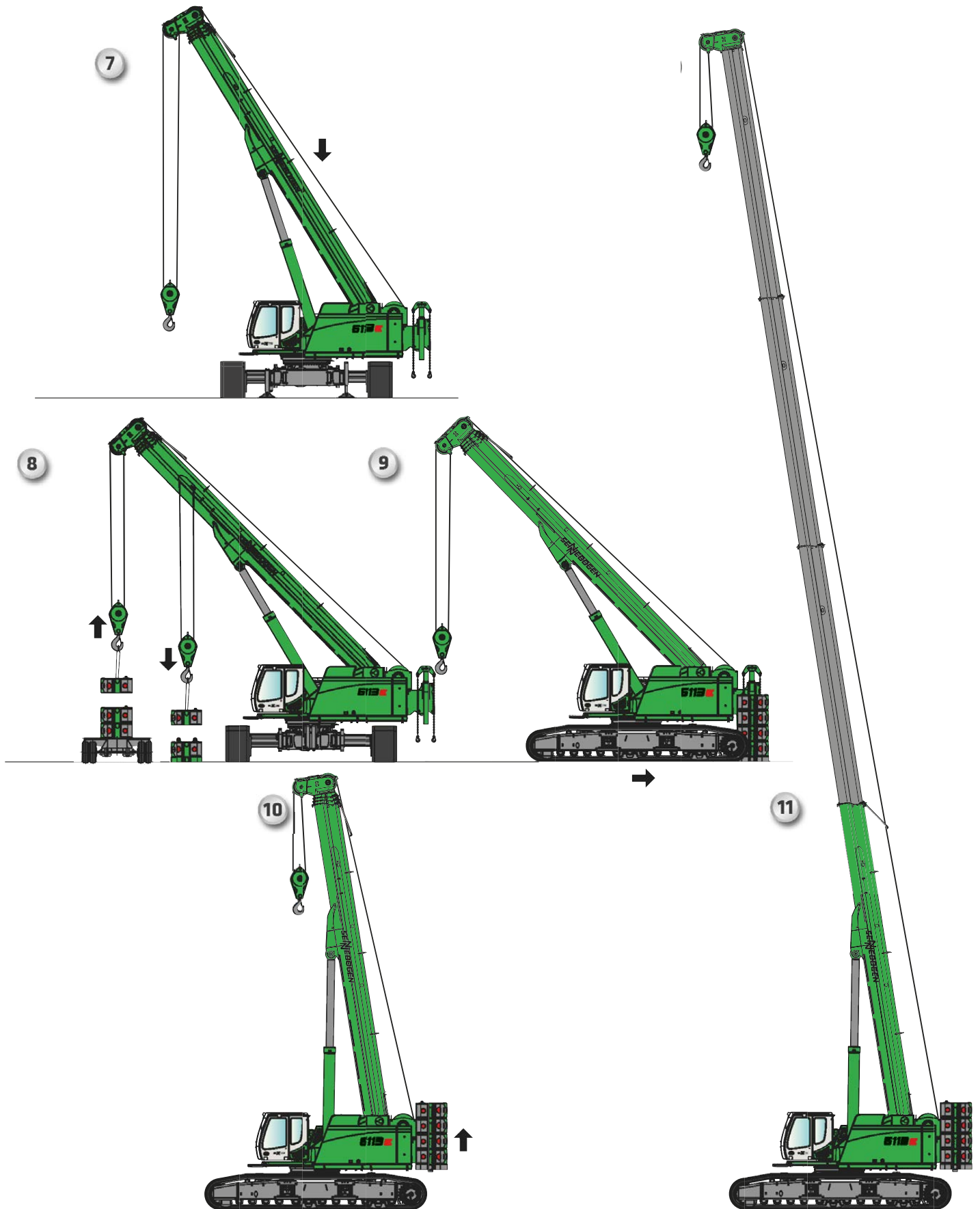

6113E Notes

A large grid of graph paper for taking notes, consisting of 20 columns and 30 rows of small squares.

6113E Notes

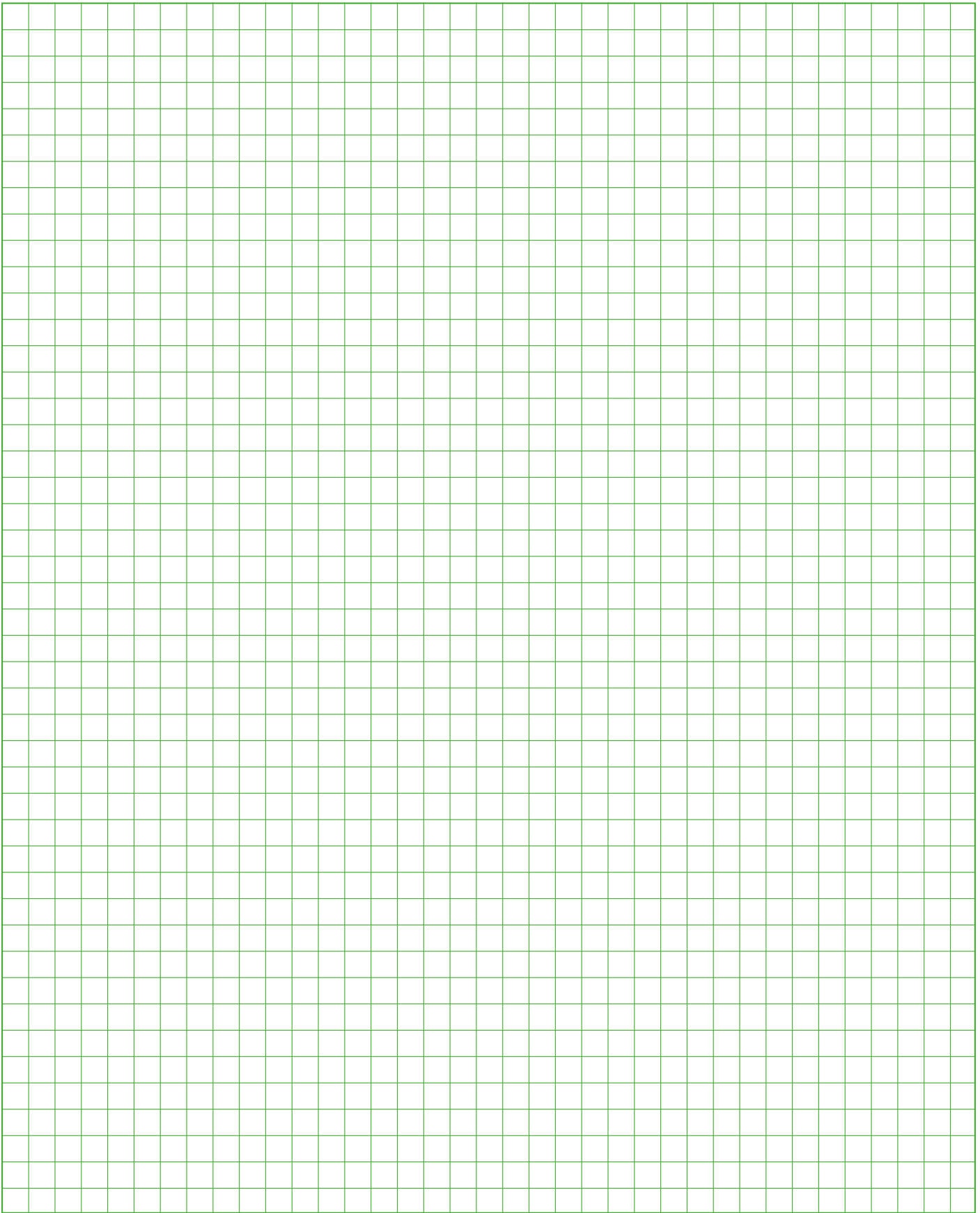

6113E

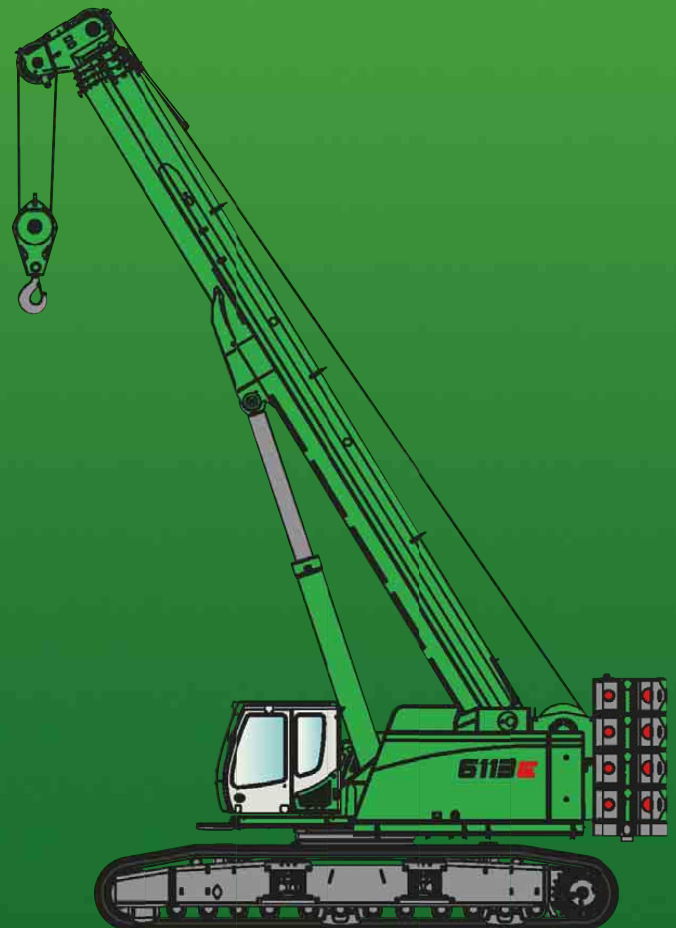

This catalog describes machine models, scope of equipment of individual models, and configuration options (standard equipment and optional equipment) of the machines delivered by SENNEBOGEN Maschinenfabrik. Machine illustrations may contain optional and additional equipment. Actual equipment may vary depending on the country to which the machines are delivered, especially in regard to standard and optional equipment.

All product designations used may be trademarks of SENNEBOGEN Maschinenfabrik GmbH or other supplying companies, and any use by third parties for their own purposes may violate the rights of the owners.

Please contact your local SENNEBOGEN sales partner for information on available equipment variants. Requested performance characteristics are only binding if they are expressly stipulated upon conclusion of the contract. Delivery options and technical features are subject to change. Errors and omissions excepted. Equipment is subject to change, and rights of advancement are reserved.

© SENNEBOGEN Maschinenfabrik GmbH, Straubing, Germany. Reproduction in whole or in part only with written consent of SENNEBOGEN Maschinenfabrik GmbH, Straubing, Germany.

SENNEBOGEN

SENNEBOGEN
Maschinenfabrik GmbH
Sennebogenstrasse 10
94315 Straubing, Germany

Phone +49 9421 540-144/146
Fax +49 942143 8-82
marketing@sennebogen.de

Order no. / Item no. 187001
6113-E-041510

GO FOR GREEN

 www.sennebogen.com