

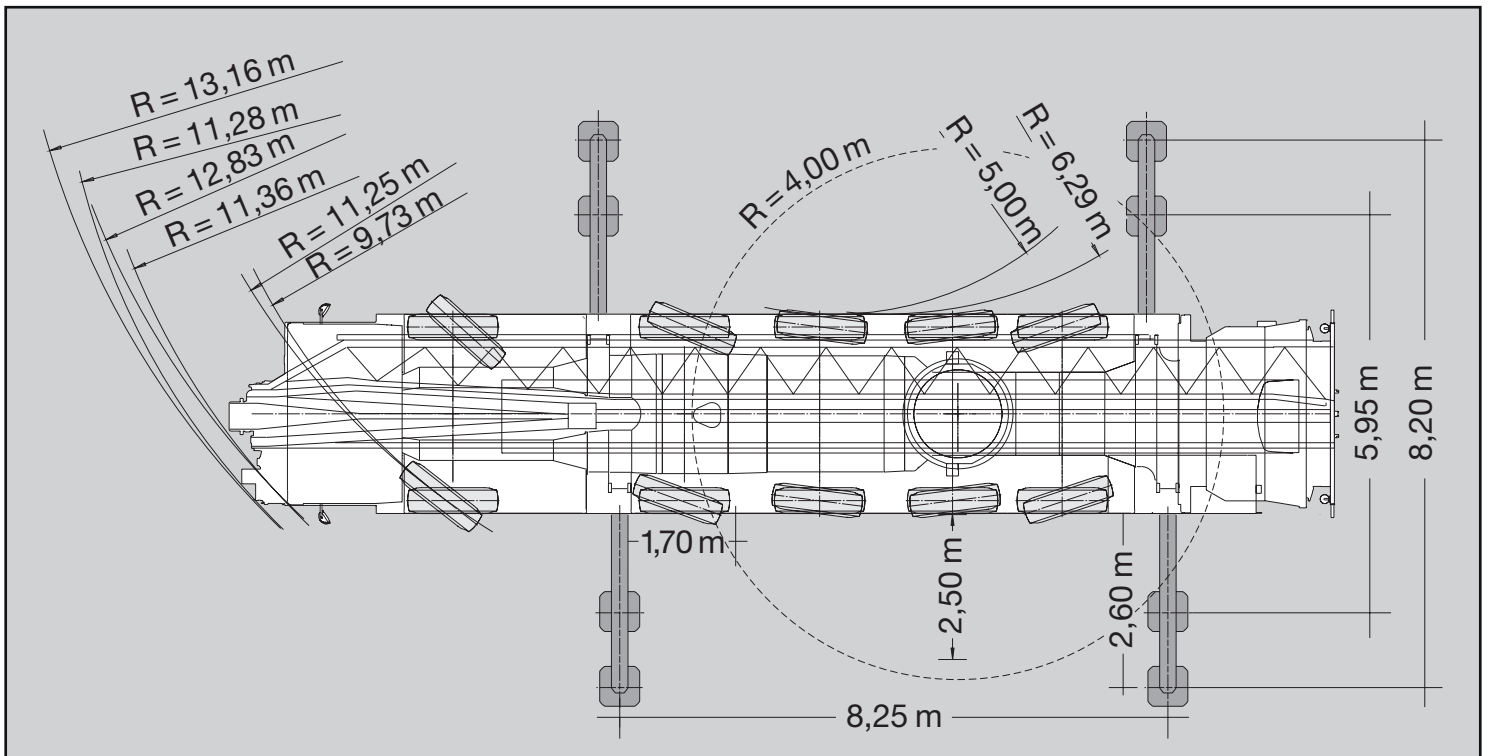

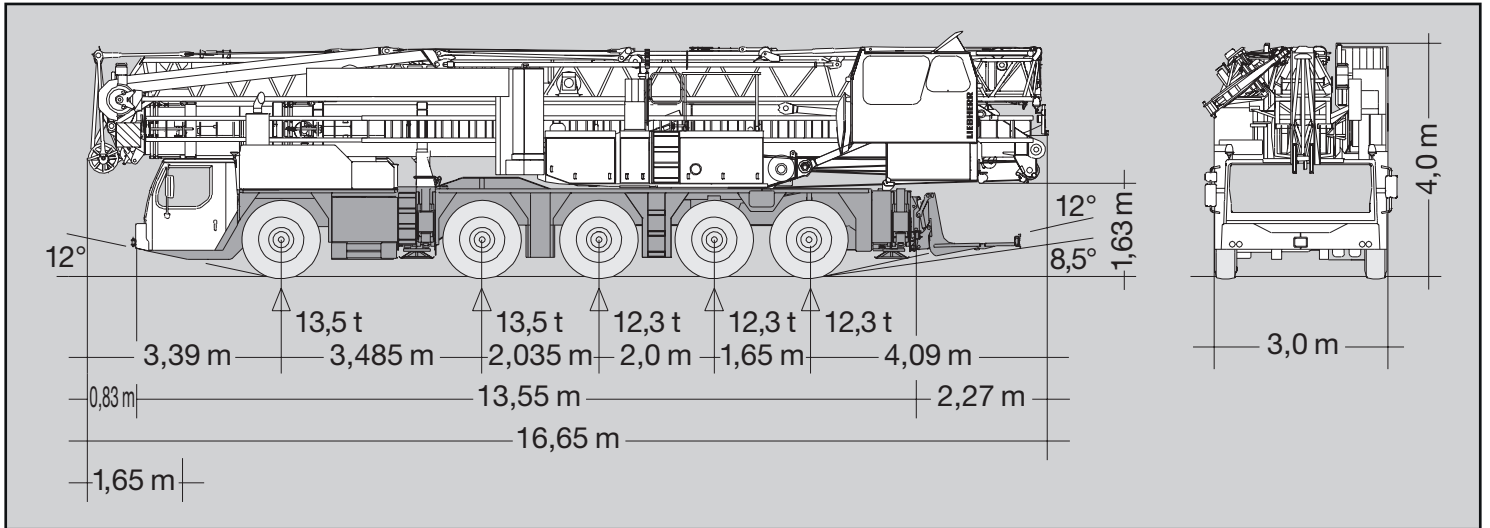

## Cotation : LIEBHERR MK 110

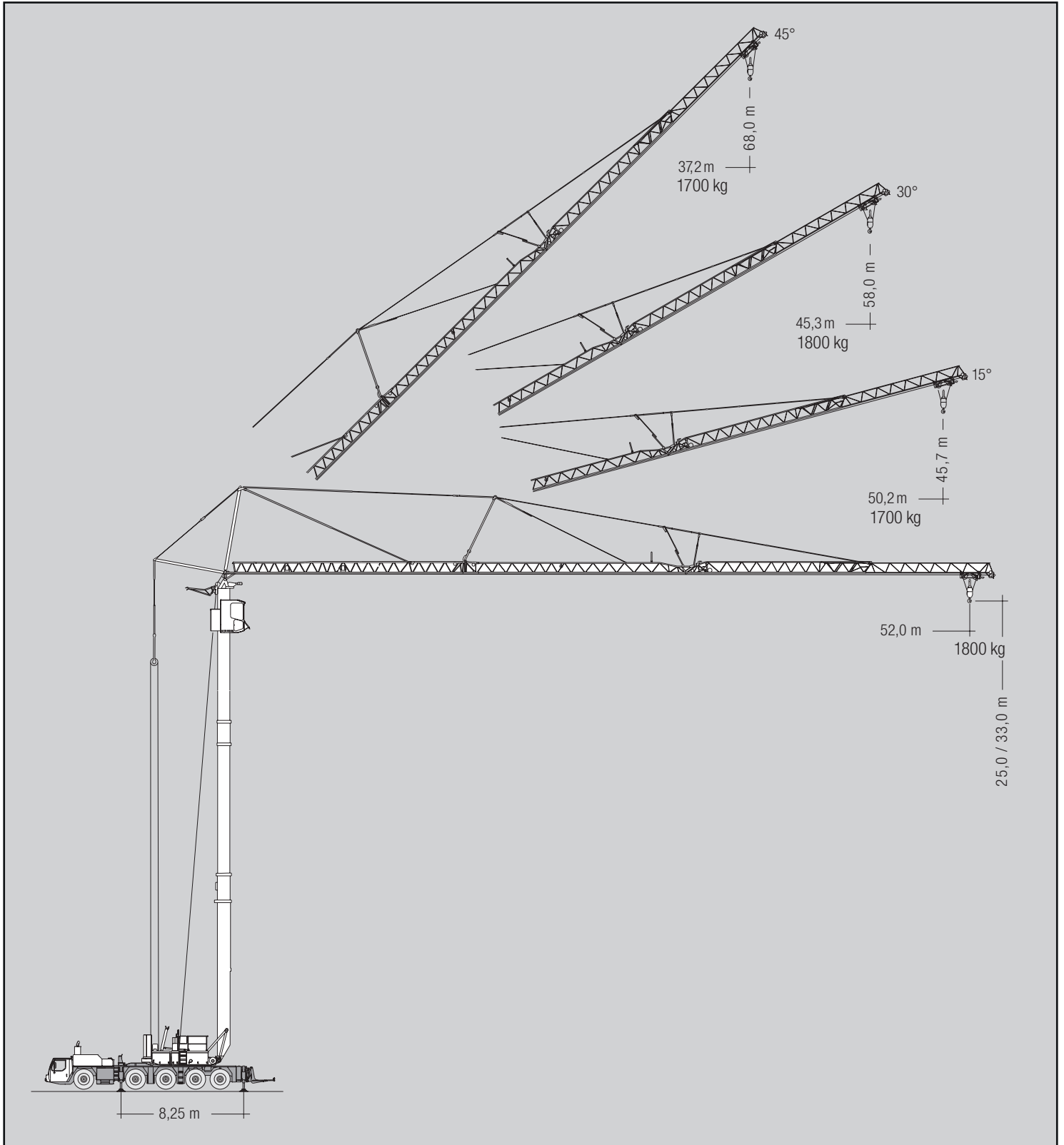





## Hauteurs et capacités de levage







## Hauteurs et capacités de levage

 8,25 m x 8,20 m	m	 m / kg	 m / kg																
			14,0	18,0	22,0	26,0	28,0	30,0	32,0	34,0	36,0	38,0	40,0	42,0	44,0	46,0	48,0	50,0	52,0
 max. 8,0 Bft (20 m/sec.)	52,0	3,4 - 14,7 8000	8000	6370	5060	4180	3830	3530	3280	3050	2850	2670	2500	2360	2230	2100	1990	1890	1800
	44,0	3,4 - 15,1 8000	8000	6550	5220	4300	3950	3640	3380	3140	2940	2750	2590	2440	2300				

 8,25 m x 8,20 m	m	 m / kg	 m 15° kg				 m 45° kg											
			 max. 8,0 Bft (20 m/sec.)	52,0		3,4 - 50,2				1700				3,4 - 37,2				1700
44,0		3,4 - 42,5				1700				3,4 - 31,5				1700				

 8,25 m x 8,20 m	m	 m / kg	 m / kg 30°																
			14,0	16,0	18,0	20,0	22,0	24,0	26,0	28,0	30,0	32,0	34,0	36,0	38,4	40,0	42,0	44,0	45,3
 max. 8,0 Bft (20 m/sec.)	52,0	3,4 - 14,7 6000	6000	5530	4930	4430	4020	3680	3380	3120	2890	2700	2520	2360	2190	2090	1970	1860	1800
	44,0	3,4 - 15,8 6000	6000	5910	5250	4710	4260	3890	3570	3290	3050	2840	2650	2480	2300				